

RC15 pressure sensors Quick Installation Guide

1. Parts and tools

Part	Pieces
Pressure sensors (RC15)	as required
Sensor cover plates (RC15-FP or PC-BP)	no. of sensors
Transfer pins	no. of sensors
Cable channel cover plate	
Smart Measuring Socket (SMS8 or SMS32)	as required
Excipients	Pieces
Countersunk head screws (M4x10)	

In addition, the installation required some basic tools and the following special tools.

Special tools
Caliper
Depth gauge
Hex key set

2. Preparations

- a) Clean the plate and the sensor pockets
- b) Check the dimensions of the sensor pocket
 - Diameter of sensor pocket - 16 mm
 - Bottom radius - MAX R0,3 mm
 - The total depth of sensor pocket - 8 mm
 - Depth of sensor body cut-out - 52 mm
 - The existence of radius'

Front installation (up), rear installation (down)

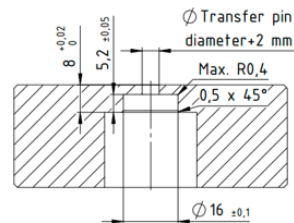
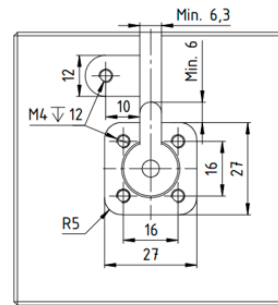
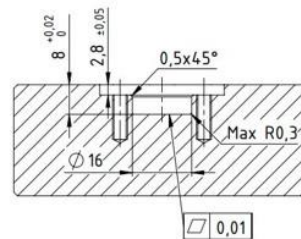
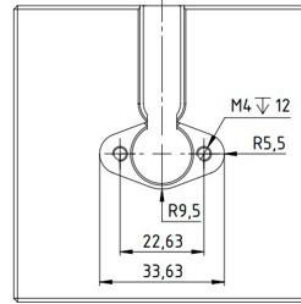

- c) Check the transfer pin hole dimensions
 - Diameter of the transfer pin's hole - 0,1 mm bigger than transfer pin's diameter
 - The counterbore around the transfer pin's hole - Height of transfer pin's head + 0,3 mm
 - Chamfer inside the counterbore
 - The counterbore diameter must be bigger than the head of the ejector pin - Min.1 mm

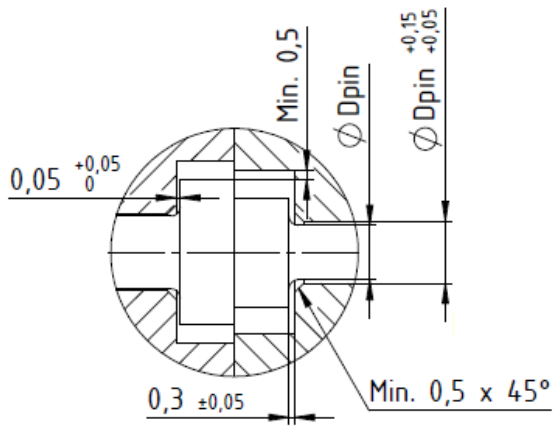

- d) Check the dimensions of the cable channel
- Depth, width
 - Check the cable channel if there is any sharp edge or missing radius
- e) Check the threads
- Socket fixing holes on the top of the plate – M5
 - Sensor front plate/back plate and cable channel cover plate fixing holes – M4

3. Installation of the sensors

- Number the sensor pockets.
- Insert the sensors into the plate.
- Write down the number of the sensor pocket and the serial number of the installed sensor onto the Sensor installation report or somewhere else.
- Check the sensor pin with the depth gauge – it must be 0,00-0,10mm under the plane of the plate. If the sensor pins' have bigger deviation than this, that means unique transfer pins will be needed.
- Fix the sensor front plates/back plates.
- Insert the cables into the cable channel and fix the cable channel cover plate.

4. Adjusting the transfer pins

- a) The table and pictures below will help you adjusting the transfer pins.

A	Highest measured sensor pin	mm
S	Lowest spacer dimension	mm

P	Lowest measured width of the ejector plate	mm
L	Calculated transfer pin length ($P + S - A - 0,02$)	mm

Front installation (up), rear installation (down)

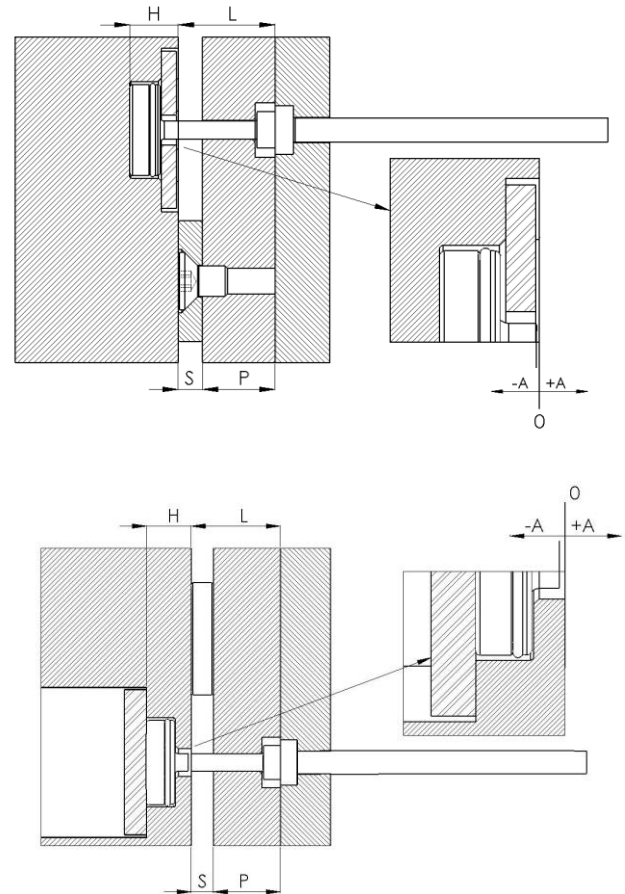

5. Further information

For further information and instructions about the sensor installation process please read our detailed **Cavity Eye – Sensor Installation Guide** or contact our support team.

*The next step in the sensor installation process is the connection of the sensor cables to the socket and fixing the socket to the mould, which you can read about in the **Cavity Eye Mould Socket Quick Installation Guide**.*